

PENTHOUSE ASSEMBLY INSTRUCTIONS

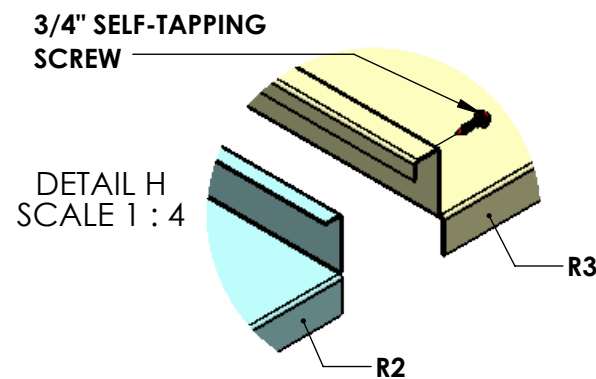

ALL 3 ROOF PANELS HAVE UNIQUE UPTURNS
 ROOF 1 HAS DOWNTURN ON S1 END
 ROOF 2 & 3 DO NOT HAVE DOWNTURNS ON LONG ENDS

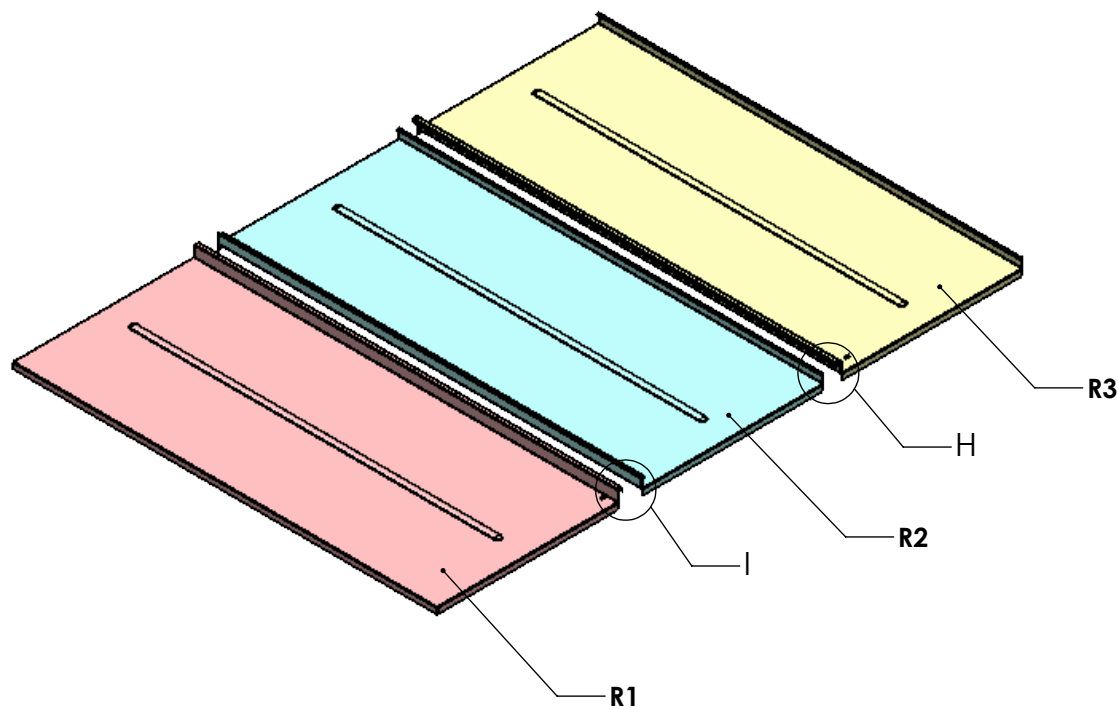
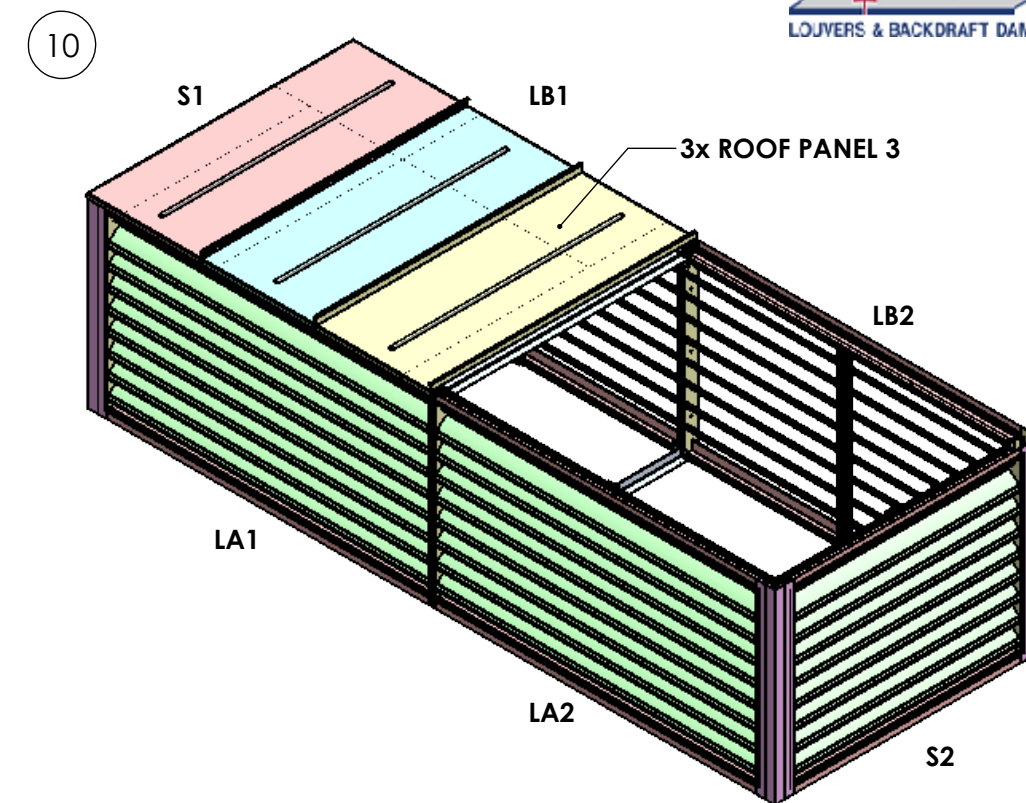
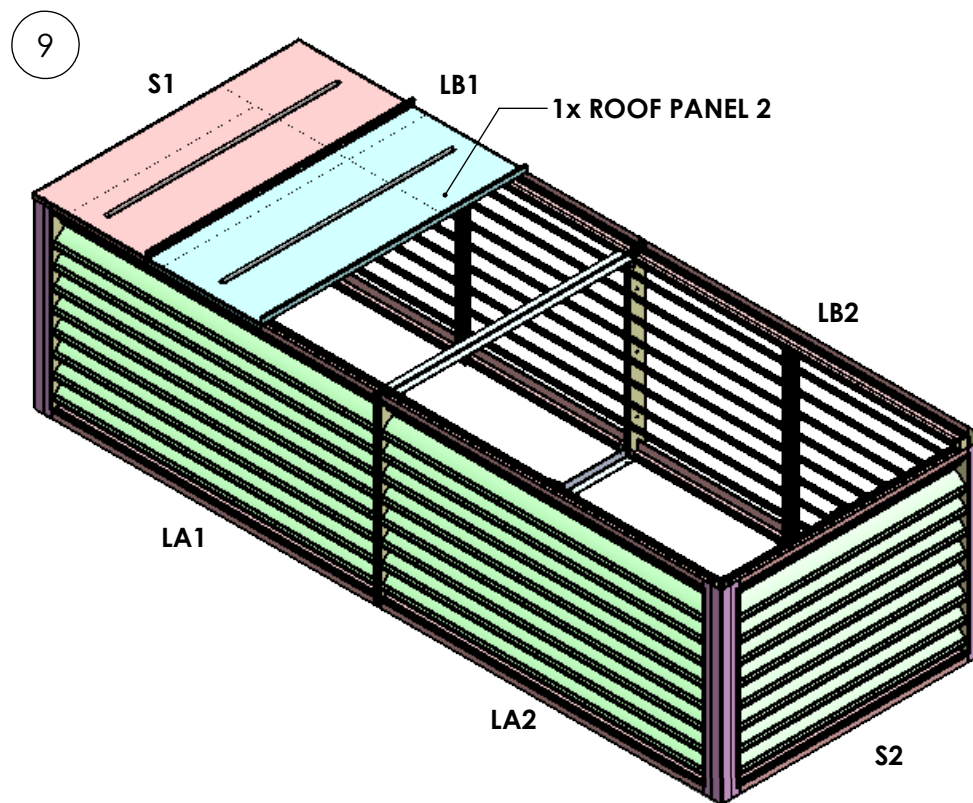
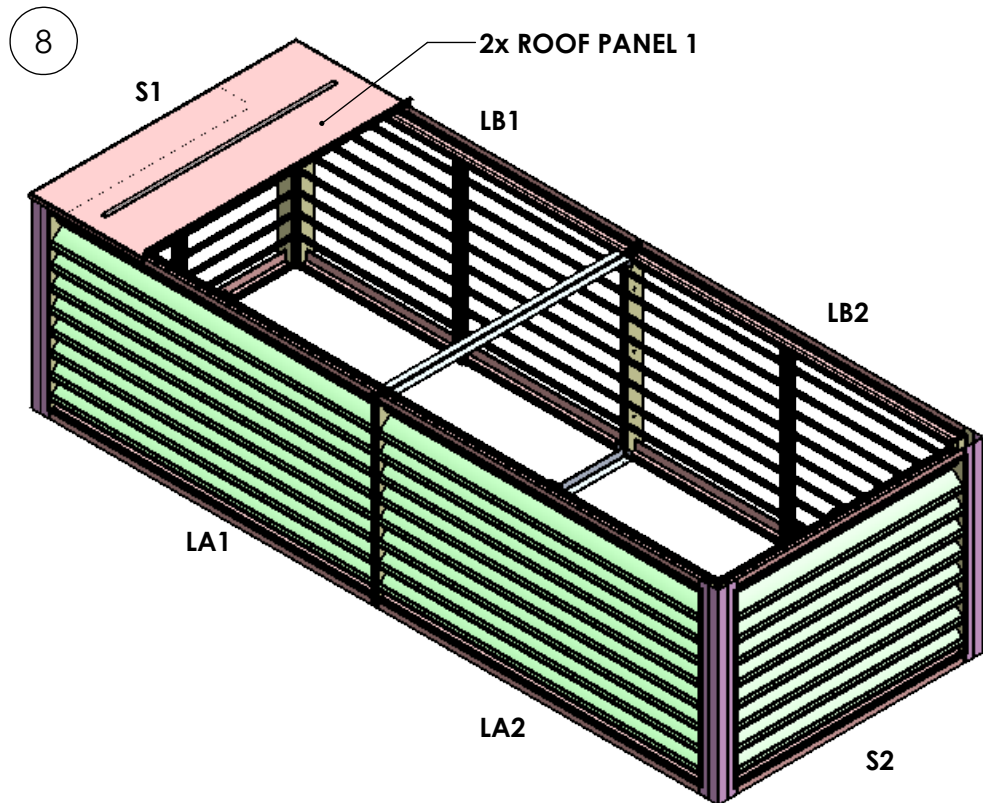
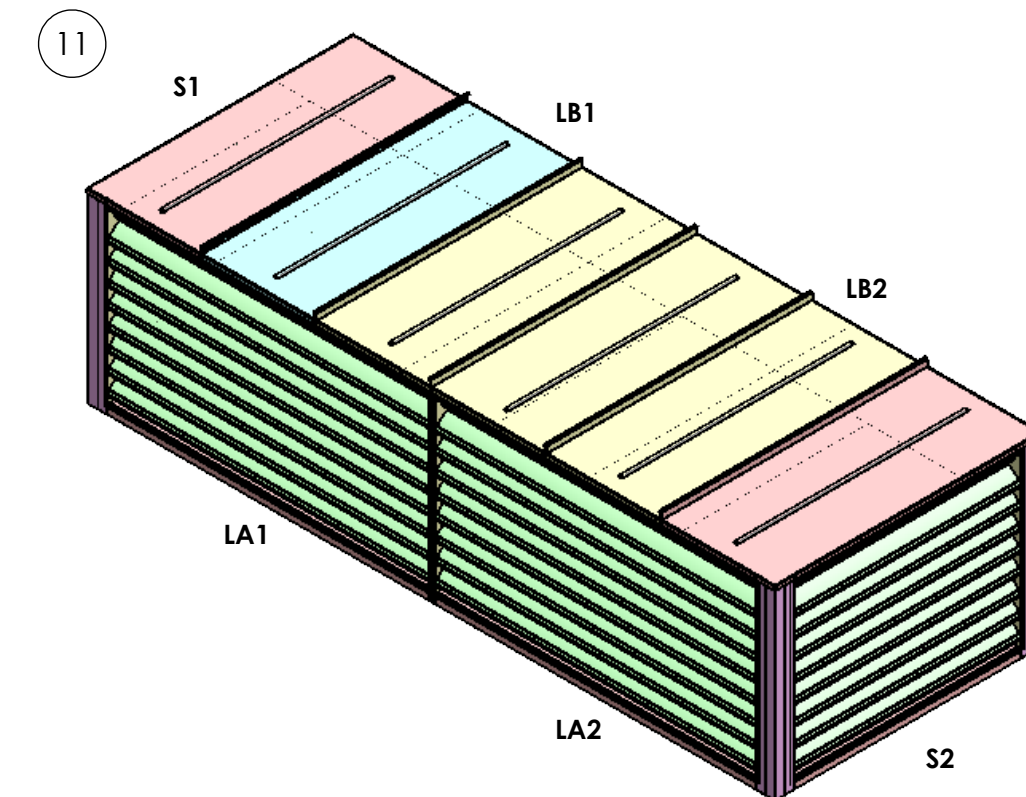
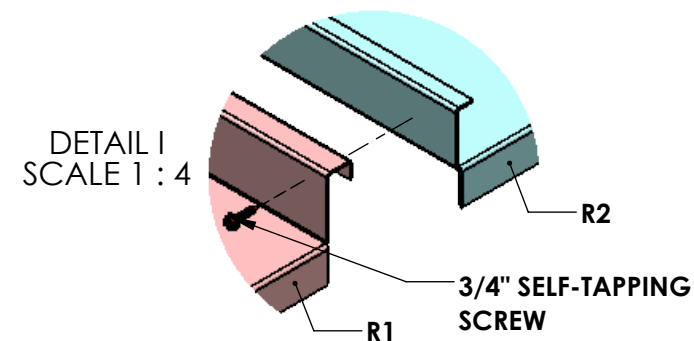

ASSEMBLE THE ROOF PANELS AS SHOWN
 SCREW THE ROOF FROM SIDES USING 3/4" SELF-TAPPING SCREW

COMPLETE PENTHOUSE ASSEMBLY