



222 Church St. S.
Alliston ON L9R 2B7
Ph: 905.857.4700
Fax: 905.857.4730
ventexinc.com

MODEL SERIES 2000 LOUVERS INSTALLATION & MAINTENANCE INSTRUCTION MANUAL

IMPORTANT! READ THESE INSTRUCTIONS COMPLETELY BEFORE PROCEEDING WITH INSTALLATION.

RECEIVING/INSPECTION

Upon receiving your louver shipment, inspect crates/containers thoroughly. If any visible damage is found, contents could also be damaged. Note any damage on the truckers delivery receipt. Contact the freight company immediately. Ventex also recommends taking photos of any damage. Ventex louvers are shipped F.O.B. the Ventex factory; it is the responsibility of the receiver of the shipment to file freight claims with the shipping company.

STORAGE/HANDLING

Louvers should be stored in their crates if possible in a safe, dry location away from construction traffic, loose materials, etc. If outside storage is necessary, crates should be elevated off the ground and securely covered with a waterproof tarp or plastic sheeting. Use care when removing louvers from crating and lift by the frame or vertical blade supports, not by the blades. If a crane, hoist or lift truck is used be sure to use a nylon sling or similar protection so as not to mar any finished surfaces. Lift at multiple points if necessary to avoid possible racking or deformation. Louvers with painted or special finishes will have a protective covering that needs to be removed before installation.

PRE-INSTALLATION

After removing louvers from crating and removing any protective coverings, do a final inspection to ensure any special finishes are unblemished and colour match is correct and that all parts are accounted for. Single-section units will be shipped fully assembled. Multi-section units will be shipped in sections for assembly on site. Measure the louver(s) to confirm correct sizing. Ventex single section louvers are undersized $\frac{1}{4}$ " (6mm) on both width and height from ordered dimensions and undersized $\frac{1}{2}$ " (13mm) overall on multi-section louvers. Measure wall openings to confirm the louver will fit properly and inspect openings for damage or obstructions that may hinder proper installation and rectify as necessary. Openings should be square and plumb.

SINGLE SECTION LOUVER INSTALLATION

If an extended sill flashing (optional by Ventex) is being utilized, make sure the opening sill surface and underside of extended sill flashing are clean and free from debris, etc. Apply caulking (by others) to the opening and set the sill flashing in place, pressing down firmly the full length of the flashing. Sill flashing may also be fastened to the sill with screws (by others). Caulk the heads of any fasteners used in order to ensure a water tight seal. *Do not caulk between the extended sill flashing and the louver sill frame.*

FASTENERS DIRECT THROUGH FRAME METHOD:

Smaller non-operable louvers may be installed utilizing screws or anchors (by others) fastened through the side of the jamb frames directly into the wall perpendicularly, providing there is adequate room between the blades, etc. for tool access. Drill appropriate holes in frame to suit fasteners. Fasteners should be located on maximum 18" (457mm) centers and maximum 6" (152mm) from corners (see Figure 1). Use shims to position the louver so that it is both level and plumb in the opening and the desired sealant gap is achieved around the full perimeter, and also to avoid any deformation when tightening fasteners. After fastening is complete, install backer rods if necessary (by others) and apply caulking (by others) around the perimeter of the louver. For flange frame models, caulking may be applied to back of flange before installing against wall.

PERIMETER CLIP ANGLE METHOD:

Locate and fasten clip angles (by others) in the opening at appropriate depth for desired off-set using appropriate fasteners (by others). Alternatively, full width/height angles may be utilized in lieu of individual clip angles. Be sure to account for any rear blade supports (usually on louvers over 60" [1524mm] wide, or over 36" [914mm] wide on thinline louvers) when locating angles. Apply a barrier (by others) on the clip angle surface that will be in contact with masonry, concrete or dissimilar metals to inhibit corrosion. Clip angles should be spaced a maximum of 18" (457mm) on center and 6" (152mm) from corners (see Figure 2). You may also pre-drill appropriately sized holes in the leg of the angles that will be fastened to the louver frame. Carefully place the louver into the opening. Use shims to position the louver so that it is both level and plumb in the opening, and the desired sealant gap is achieved around the full perimeter. When the louver is in the appropriate position, fasten the clip angles to the louver frame using minimum #12 x $\frac{3}{4}$ " stainless steel self-tapping sheet metal screws. After fastening is complete, install backer rods if necessary (by others) and apply caulking (by others) around the perimeter of the louver. For flange frame models, caulking may be applied to back of flange before installing against wall.

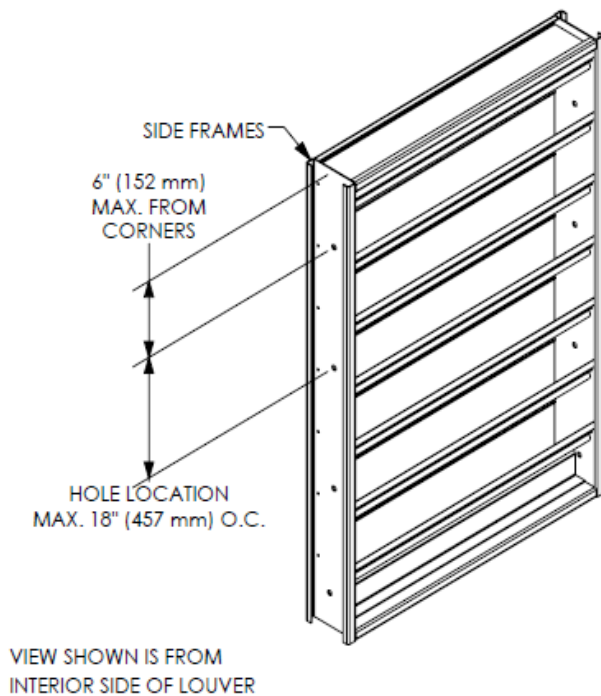

FIGURE 1

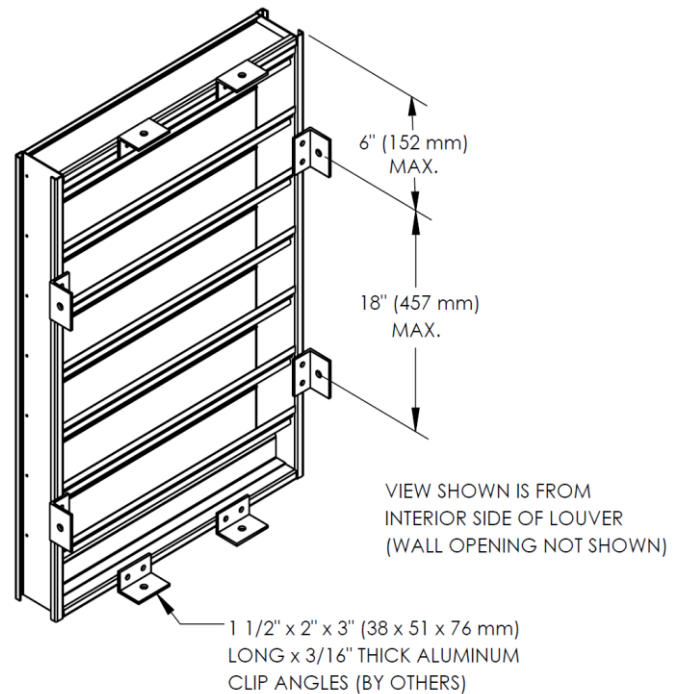

FIGURE 2

MULTIPLE SECTION ASSEMBLY INSTALLATION

Larger multiple section assemblies usually require rear structural bracing (by others) to support the weight of the assembly and specified wind loads. Vertical structural bracing should be one continuous piece from top to bottom of opening. Ventex can supply drawings indicating positions of louver mullions and rear blade support carriers for coordination of structural bracing positioning.

IMPORTANT NOTE: All fasteners shown in these instructions are suggested minimum. Always follow job specific engineering drawings and specifications for appropriate fasteners to be used.

If an extended sill flashing (optional by Ventex) is being utilized, make sure the opening sill surface and underside of extended sill flashing are clean and free from debris, etc. Apply caulking (by others) to the opening and set the sill flashing in place, pressing down firmly the full width of the sill flashing. Sill flashing may also be fastened to the sill with screws (by others). Caulk the heads of any fasteners used in order to ensure a water tight seal. Do not caulk between the extended sill flashing and the louver sill frame.

VISIBLE MULLION CONSTRUCTION:

Locate and fasten clip angles (by others) in the opening at appropriate depth for desired off-set using appropriate fasteners (by others). Alternatively, full width/height angles may be utilized in lieu of individual clip angles. Be sure to account for any rear blade supports (usually on individual sections over 60" [1524mm] wide, or over 36" [914mm] wide on thinline louvers) and additional structural supports when locating angles. Apply a barrier (by others) on the clip angle surface that will be in contact with masonry, concrete or dissimilar metals to inhibit corrosion. Clip angles should be spaced a maximum of 18" (457mm) on center and 6" (152mm) from corners (see Figure 2). You may also pre-drill appropriately sized holes in the leg of the angles that will be fastened to the louver frame.

For louver assemblies that are single section high/multiple sections wide, install the left section first (as viewed from building exterior), then other sections progressively working from left to right. Use shims to position the louver so that it is both level and plumb in the opening and the desired sealant gap is achieved at the perimeter. When the louver is in the appropriate position, fasten perimeter louver frame to clip angles, and any rear intermediate mullions/blade supports to structural bracing using minimum #12 x 1" stainless steel self-tapping sheet metal screws (by others) spaced on maximum 18" (457mm) centers. For taller vertical mullions (fixed blade louvers only) where no bracing is present, mullion frames may be fastened together directly as necessary using minimum 1/4" dia. x 2 1/2" long bolts with lock nuts and washers spaced on maximum 18" (457mm) centers (see Figures 3 and 4). After fastening is complete, install backer rods if necessary (by others) and apply caulking (by others) around the perimeter of the louver.

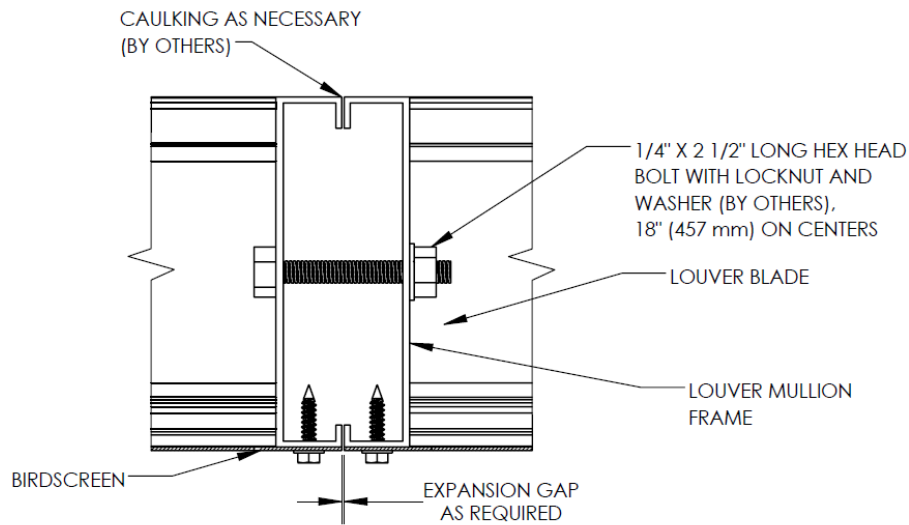

PLAN VIEW

FIGURE 3

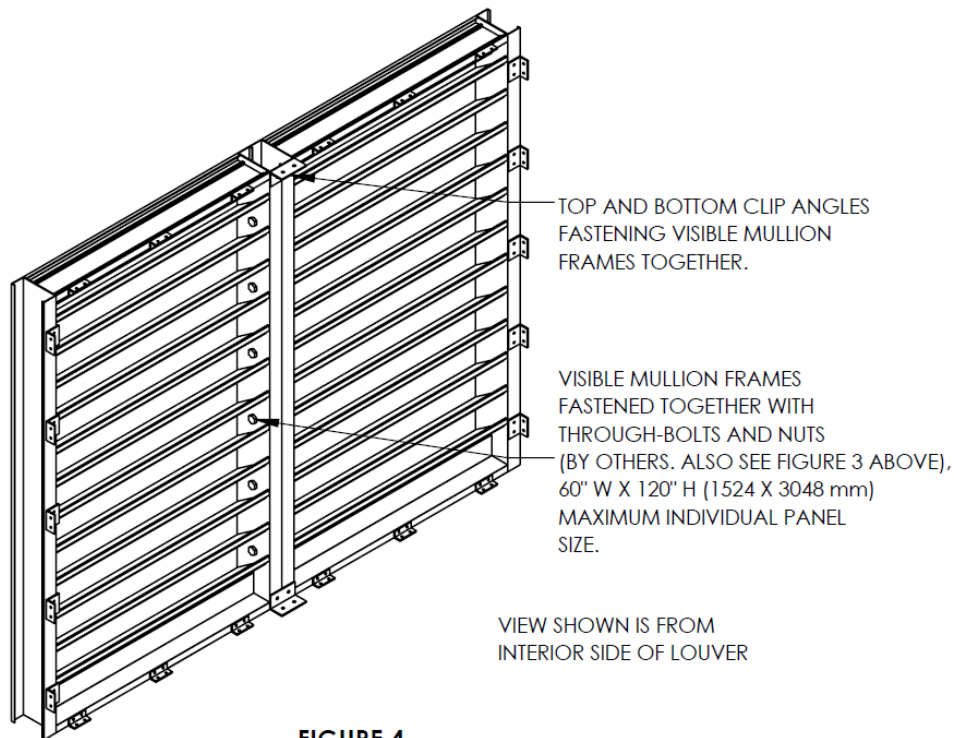

FIGURE 4

For louver assemblies that are multiple sections wide/multiple sections high, install the lower sections first. Start with the far left section (as viewed from building exterior), then other sections progressively working from left to right. Use shims to position the louver so that it is level and plumb in the opening and the desired sealant gap is achieved at the perimeter. When the louver is in appropriate position, fasten perimeter louver frame to clip angles, and any rear mullions/blade supports to structural bracing using minimum #12 x 1" stainless steel self-tapping sheet metal screws (by others) on maximum 18" (457mm) centers. Repeat process for upper sections. A thin bead of caulking may be applied between upper and lower jamb frame sections to ensure water tightness, especially on drainable louvers. Upper and lower sections may be fastened together using splice angles (by others) fastened to side jamb frames (**see Figure 5**). After fastening is complete, install backer rods if necessary (by others) and apply caulking (by others) around perimeter of frame.

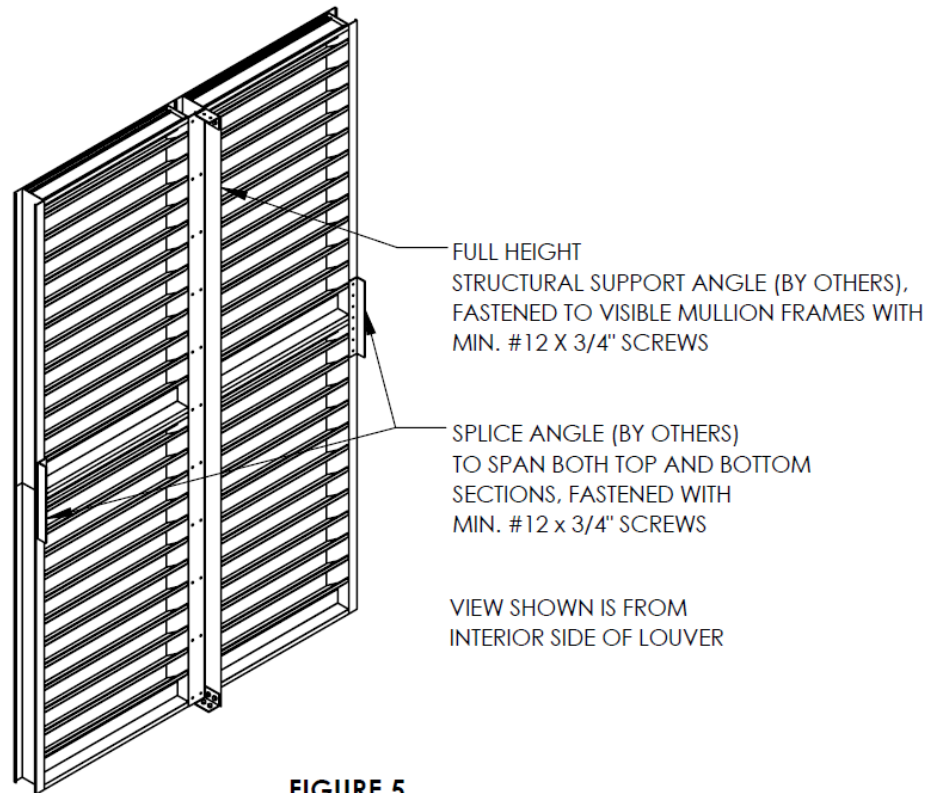

FIGURE 5

CONCEALED ARCHITECTURAL MULLION (CONTINUOUS LINE) CONSTRUCTION:

Locate and fasten clip angles (by others) in the opening at appropriate depth for desired off-set using appropriate fasteners (by others). Alternatively, full width/height angles may be utilized in lieu of individual clip angles. Be sure to account for any rear blade supports (usually on individual sections over 60" [1524mm] wide, or over 36" [914mm] wide on thinline louvers) and additional structural supports when locating angles. Apply a barrier (by others) on the clip angle surface that will be in contact with masonry, concrete or dissimilar metals to inhibit corrosion. Clip angles should be spaced a maximum of 18" (457mm) on center and 6" (152mm) from corners (see Figures 2 and 9). You may also pre-drill appropriately sized holes in the leg of the angles that will be fastened to the louver frame.

Note: Concealed mullion multi-section wide louvers are shipped with a temporary end plate to maintain blade alignment during shipping. This plate must be removed prior to installation and can be discarded.

For louver assemblies that are single section high/multiple sections wide, install the left section first (as viewed from building exterior), then other sections progressively working from left to right. Use shims to position the louver so that it is both level and plumb in the opening and the desired sealant gap is achieved at the perimeter. When the louver is in the appropriate position, fasten perimeter louver frame to clip angles, and any rear intermediate mullions/blade supports to structural bracing, using minimum #12 x 1" stainless steel self-tapping sheet metal screws (by others). After removing the temporary end plate from the second section, install the section, aligning the blade ends with the corresponding blade support brackets factory installed on the first section, guiding the top of each blade up into the top track of each blade support bracket (see Figure 6). Firmly push center of each blade end to snap the integral blade boss into hook of blade bracket. Secure each blade to bracket and carrier using #12 x 1" (25mm) stainless steel self-tapping sheet metal screw (by others) (see Figures 6 and 7). Section should be positioned to provide appropriate expansion gap between ends of blades. Repeat process for additional sections. After fastening is complete, install backer rods if necessary (by others) and apply caulking (by others) around perimeter of frame.

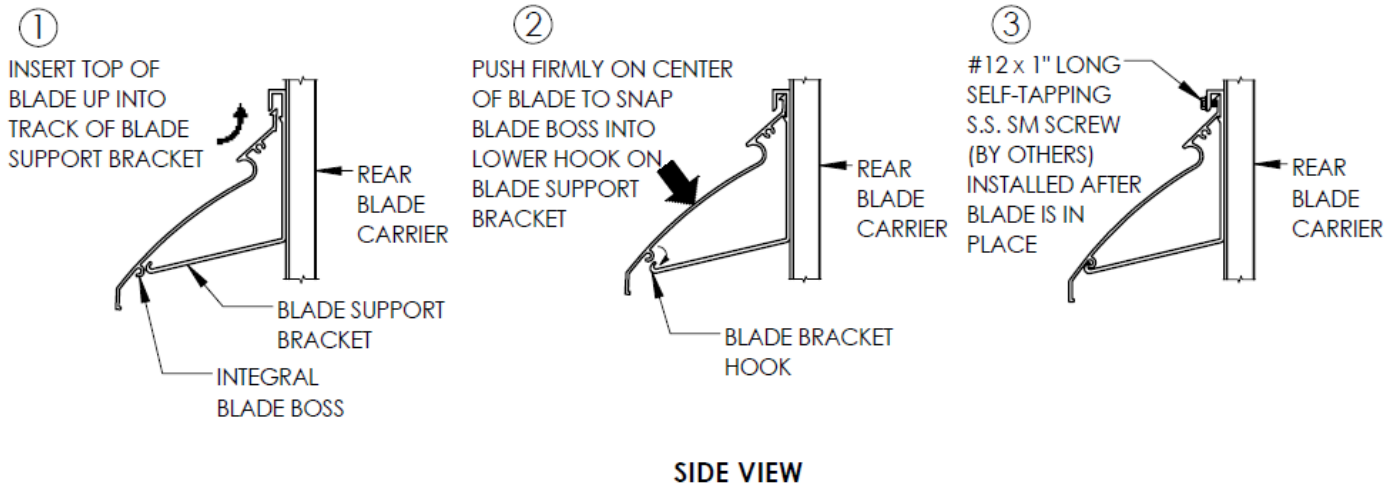

SIDE VIEW

FIGURE 6

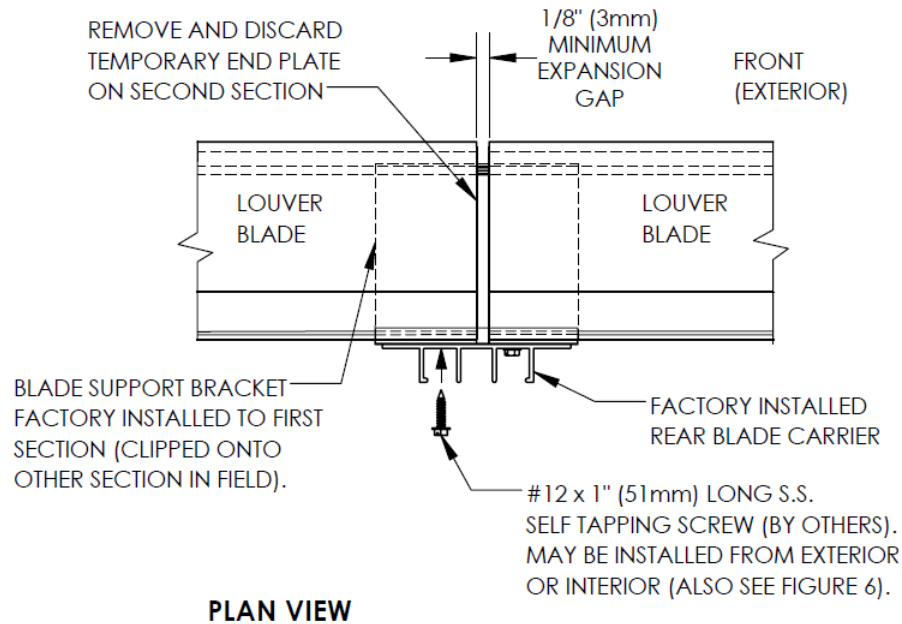

PLAN VIEW

FIGURE 7

For louver assemblies that are multiple sections wide/multiple sections high, install the lower sections first. Start with the far left section (as viewed from building exterior), then other sections progressively working from left to right (**see Figure 8**). Use shims to position the louver so that it is level and plumb in the opening and the desired sealant gap is achieved at the perimeter. When the louver is in the appropriate position, fasten perimeter louver frame to clip angles, and any rear intermediate mullions/blade supports to structural bracing, using minimum #12 x 1" stainless steel self-tapping sheet metal screws (by others). After removing the temporary end plate from the second section, install the section, aligning the blade ends with the corresponding blade support brackets factory installed on the first section, guiding the top of each blade up into the top track of each blade support bracket (**see Figure 6**). Firmly push center of each blade end to snap the integral blade boss into hook of blade bracket. Secure each blade to bracket and carrier using #12 x 1" (25mm) stainless steel self-tapping sheet metal screw (by others) (**see Figures 6 and 7**). Section should be positioned to provide appropriate expansion gap between ends of blades. Repeat process for upper sections. A thin bead of caulking may be applied between upper and lower side jamb frame sections to ensure water tightness, especially on drainable louvers. Upper and lower sections may be fastened together at side jamb frames using splice angles. Secure upper and lower rear blade carriers to structural bracing using minimum #12 x 1-1/2" stainless steel screws (by others) (**see Figure 9**). After fastening is complete, install backer rods if necessary (by others) and apply caulking (by others) around perimeter of frame.

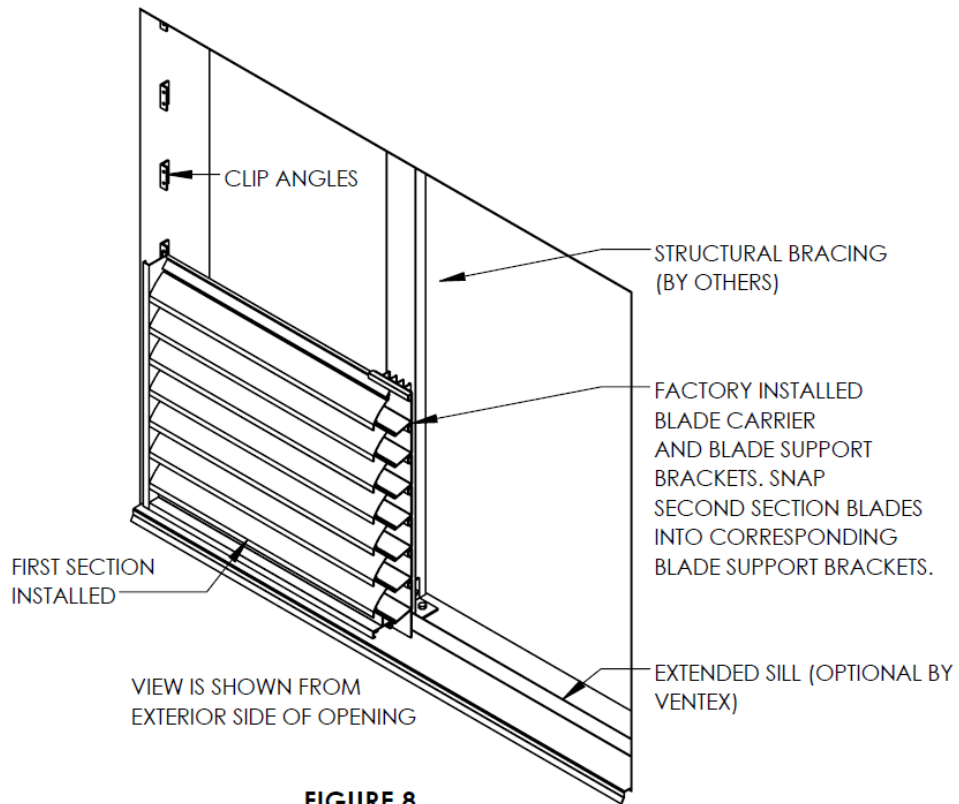

FIGURE 8

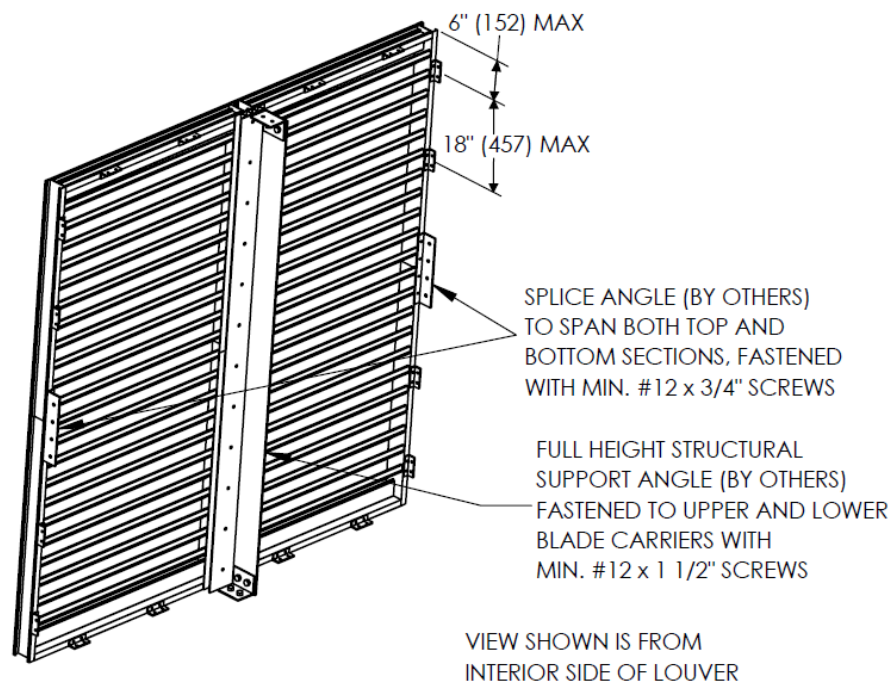

FIGURE 9

MAINTENANCE

In general, louvers require very little maintenance. All louvers should be checked and serviced on a regular schedule. Inspection intervals depend on the system usage and atmospheric conditions. Today's high quality painted and anodized finishes are extremely durable but still require some degree of maintenance to ensure a long life.

PAINTED FINISHES:

Louvers should be cleaned with a mild soap solution that is not caustic or corrosive. Avoid the use of strong acid or alkali cleaners as they may damage the finish. Solvents such as denatured alcohol or mineral spirits may be used to remove sealants, grease or other similar foreign materials but should be wiped clean and rinsed immediately. Do not use abrasive cleaners or abrasive materials (ie: steel wool or steel brush, etc.) which can harm the finish. Once sealant, grease, etc. are removed, the mild soap solution can be applied using a soft sponge, cloth or brush. Rinse the surface thoroughly with clean water and let air dry or wipe with a clean chamois.

ANODIZED FINISHES:

Anodized material has an extremely hard surface that is very colourfast and mar resistant. Much like painted surfaces, an anodized finish should be cleaned using a mild soap solution applied with a soft sponge, cloth or brush and rinsed thoroughly. Severely soiled anodized surfaces can be cleaned a little more aggressively than painted surfaces. For example, slight scuff marks and rub marks can be removed with a mild abrasive pad such as a Scotch-Brite pad. Rub lightly as needed to remove the mark then clean the surface using the mild soap solution. Rinse the surface thoroughly with clean water and let air dry or wipe with a clean chamois.

GENERAL MAINTENANCE:

Bird screens and insect screens should be checked for particulate build-up such as leaves, insects, etc. and should be cleaned regularly to ensure optimum air performance. Drainable louvers have gutters that should be cleaned out regularly to ensure proper water-shedding.

OPERABLE LOUVERS:

Operable or adjustable louvers require more maintenance than fixed-blade louvers due to the additional movable parts. All linkages, pins, shafts, fasteners and actuator connections should be checked for wear and proper movement and alignment. Wear surfaces should be lubricated with a dry, light moly-lubricant.